

**FOUR PLATE ASSEMBLY**

**LIST OF PARTS**

- ① — 1/2" CAP NUT ZINC ALLOY
- ② — CENTER ROD FOUR PLATE 19 1/2"
- ③ — 6" FEMALE SEPARATOR ALUMINUM
- ④ — 6" MALE SEPARATOR ALUMINUM
- ⑤ — ALUMINUM PLATE NUT NO. 8 HEX. OR RIVITS
- ⑥ — ALUMINUM PLATE BOLT NO. 8 X 1/2" PHILLIPS HEAD
- ⑦ — STREET NAME SIGN ADAPTER

**NOTE**  
SIGN LOCATION TO BE DETERMINED BY THE CITY ENGINEER. NAME PLATES AND MOUNTING ASSEMBLIES TO MEET THE REQUIREMENTS OF THE CITY ENGINEER.

NO.	REVISED	DATE
REVISIONS		

**CITY OF FREMONT**  
STANDARD DETAILS  
**STREET NAME SIGN**  
AND POST DETAILS

DATE APPROVED BY CITY COUNCIL  
04/11/06

RESOLUTION NO. 2006-31

*Ham Hughes*

CITY ENGINEER

FILE NO. SD-26-05.DWG	SCALE NONE	DRAWN DC	CHECKED KC	DATE 03/14/06	DWG NO. SD-23	1 of 3
--------------------------	---------------	-------------	---------------	------------------	------------------	--------

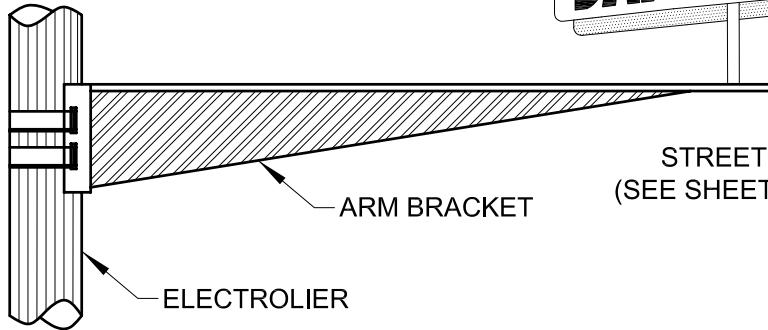
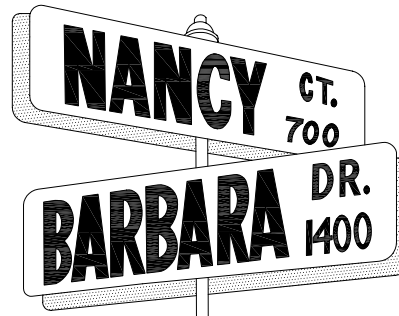

STREET NAME SIGNS  
(SEE SHEET 1 FOR DETAILS)

ARM BRACKET

ELECTROLIER

ASSEMBLED BRACKET

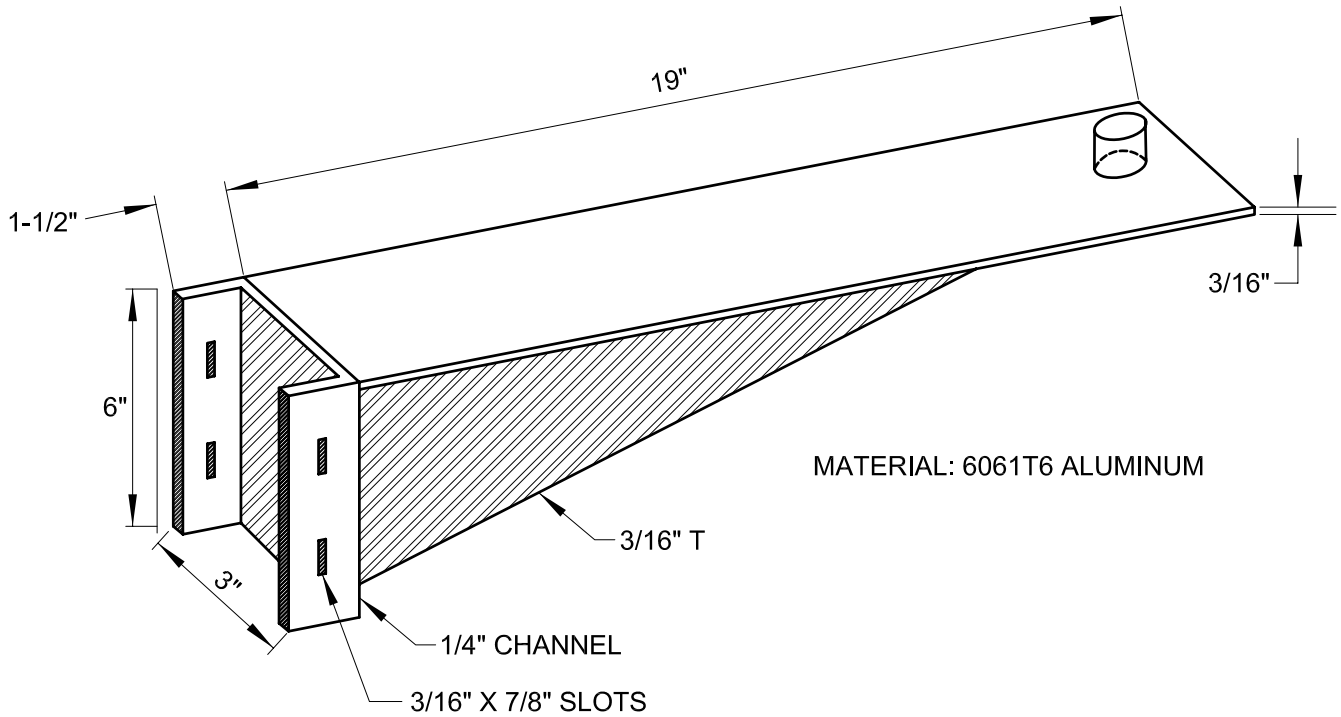

MATERIAL: 6061T6 ALUMINUM

3/16" T

1/4" CHANNEL

3/16" X 7/8" SLOTS

ARM BRACKET FOR ELECTROLIER

NO.	REVISED	DATE
REVISIONS		

**CITY OF FREMONT**  
STANDARD DETAILS  
STREET NAME SIGN  
AND POST DETAILS

DATE APPROVED BY CITY COUNCIL  
04/11/06

RESOLUTION NO. 2006-31

*Ham Hughes*

CITY ENGINEER

FILE NO. SD-26-05.DWG	SCALE NONE	DRAWN DC	CHECKED KC	DATE 03/14/06	DWG NO. SD-23	2 of 3
--------------------------	---------------	-------------	---------------	------------------	------------------	--------

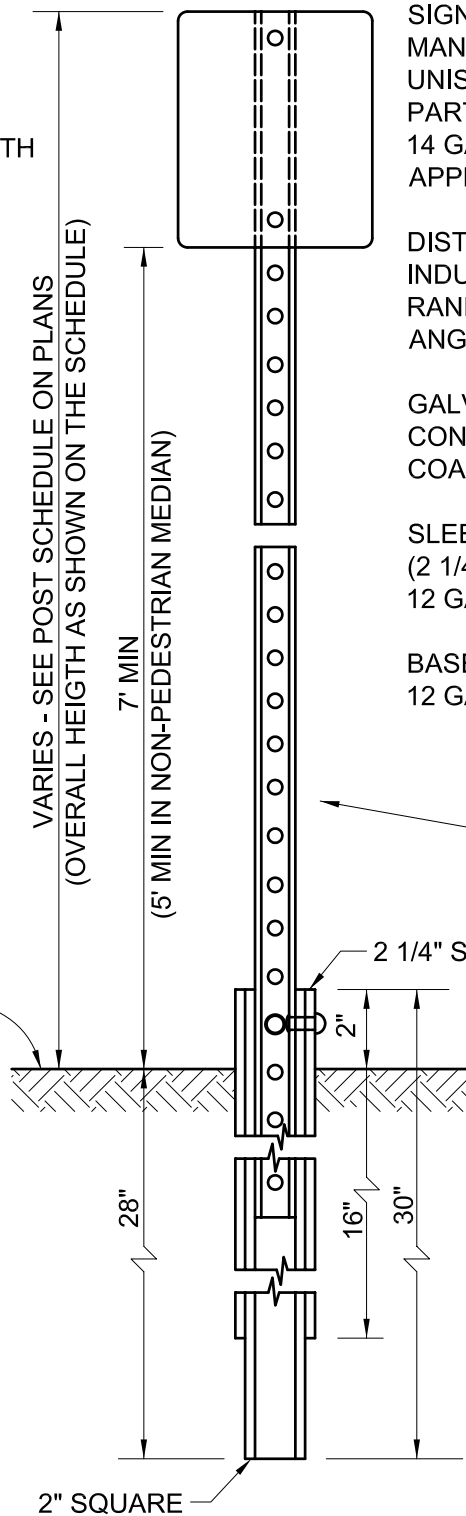
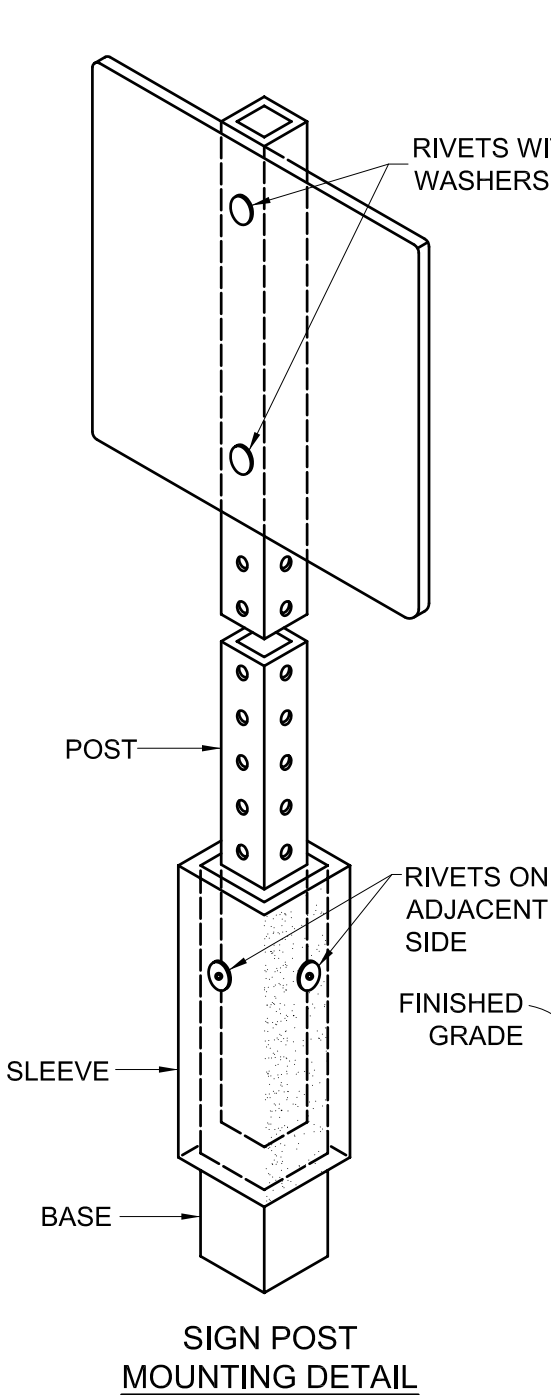

SIGN POST SHALL BE MANUFACTURED BY UNISTRUT CORPORATION. PART NO. 16D12 (1 3/4 X 1 3/4) 14 GA. GALV. POST OR APPROVED EQUAL

DISTRIBUTION BY ZUMAR INDUSTRIES, INC. 6371 RANDOLPH STREET, LOS ANGELES, CA 90040.

GALVANIZED FINISH TO CONFORM TO ASTM A525 G90 COATING.

SLEEVE SHALL BE A653 (2 1/4" X 2 1/4" X 18") 12 GA. GALV. STEEL.

BASE SHALL BE (2" X 2" X 30") 12 GA. GALV. STEEL.

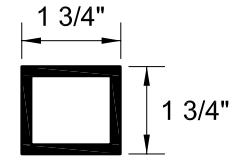

WEIGHT= 1.45 LB/FT

2 1/4" SQUARE

POST SHALL BE PRODUCED FROM HIGH STRENGTH RAIL STEEL ACCORDING TO ASTM A715, GRADE 60.

**CITY OF FREMONT**  
STANDARD DETAILS  
**TRAFFIC SIGN POST**

DATE APPROVED BY CITY COUNCIL  
04/11/06

RESOLUTION NO. 2006-31

*Ham Hughes*

CITY ENGINEER

NO.	REVISED	DATE
REVISIONS		

FILE NO. SD-26-05.DWG	SCALE NONE	DRAWN DC	CHECKED KC	DATE 03/08/06	DWG NO. SD-23	3 of 3
--------------------------	---------------	-------------	---------------	------------------	------------------	--------